

Dinamometro a cable de Acero 3 Ton IP68

Características Esenciales

- 3 Años de Garantía, Partes y Servicios Disponibles en América

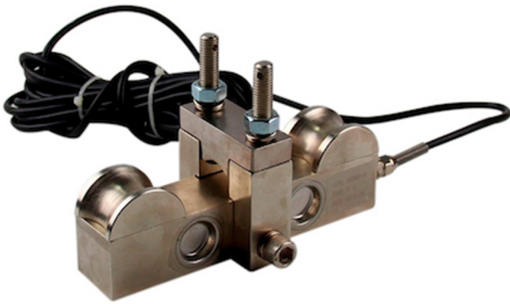

Especificaciones Técnicas

Capacidad de Carga	6000 lb / 3 ton	Excitación Recomendada	5-12V
Balance Cero	±1% FS, TCO = ±0.05% FS 50 °F / 10 °C	Excitación Máxima	15V
Impedancia de Entrada	385 ± 5 Ω	Protección Antiexplosión	EX I a II CT6
Impedancia de Salida	350 ± 2 Ω	Sensibilidad del Receptor	1.0 mv/v
Impedancia de aislamiento	≥5000M Ω	Protección IEC Motor	IP68
Máxima Sobrecarga Segura	150% FS	Garantía	3 Year
Sobrecarga Maxima	200% FS		

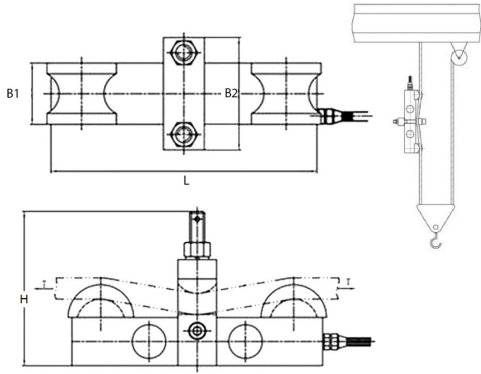

Capacity / Capacidad	H	B1	B2	L	Steel Rope/Cable de Acero
2000 lb / 1 t	3.8 in / 95.5 mm	1.6 in / 40 mm	2.4 in / 60 mm	7.1 in / 180 mm	ø1/4 - ø9/16 in ø6 - ø14 mm
4000 lb / 2 t	3.8 in / 95.5 mm	1.6 in / 40 mm	2.4 in / 60 mm	7.1 in / 180 mm	ø25/64 - ø54/64 in ø10 - ø18 mm
6000 lb / 3 t	3.8 in / 95.5 mm	1.6 in / 40 mm	2.4 in / 60 mm	7.1 in / 180 mm	ø15/32 - ø25/32 in ø12 - ø20 mm
10000 lb / 5 t	5.4 in / 136.5 mm	1.6 in / 40 mm	2.9 in / 75 mm	7.9 in / 200 mm	ø5/8 - ø1 1/32 in ø16 - ø26 mm
20000 lb / 10 t	7.7 in / 195 mm	2.4 in / 60 mm	4.3 in / 110 mm	10.2 in / 260 mm	ø15/16 - ø1 13/32 in ø24 - ø36 mm
50000 lb / 25 t	By Request Customizable / Adaptable Según Pedido				
100000lb / 50 t	By Request Customizable / Adaptable Según Pedido				

Referential Images / Imágenes Referenciales
 Specifications may change without notice / las especificaciones pueden cambiar sin previo aviso