



5 Ton Manual Gantry Crane 11~15 ft Height 8 ft Span **MADE IN USA**

Características Esenciales

- 3 Años de Garantía, Partes y Servicios Disponibles en América

Especificaciones Técnicas

Capacidad de Carga	5 ton	Material	Steel
Alto de Viga	21 in	Factor de Diseño	4:1
Overall SPAN	8 ft	Rango de ancho de la Viga	8.24 in
Clear SPAN	6 ft	Fabricado en	USA
HUB Altura Libre Bajo la Viga	11 to 15 ft	Garantía	3 Year

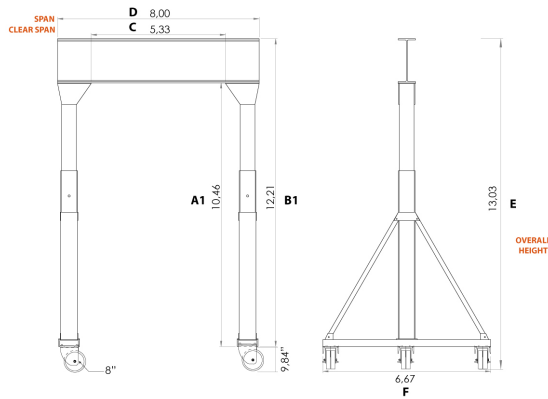

MODEL	PWSG5T-S8-H11-15a
A1	10,46 ft
B1	12,21 ft
C	5,5 ft
D	8,0 ft
E	13,03 ft
A2	12,21 ft
B2	15,03 ft
F	6,6 ft
G	15,82 ft

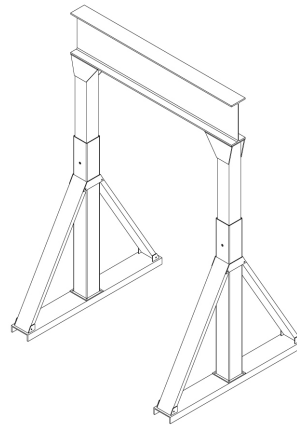
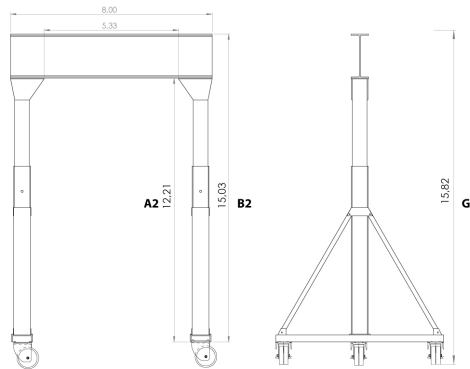

Referential Images / Imágenes Referenciales
 Specifications may change without notice / las especificaciones pueden cambiar sin previo aviso