



## Permanent Magnetic Lifter 220 lb. / 100 kg

### Características Esenciales

- 3 Años de Garantía, Partes y Servicios Disponibles en América

## Especificaciones Técnicas

<b>Capacidad de Carga</b>	220 lb / 100 kg   Max. pull off: 660 lb / 300 kg	<b>Garantía</b>	3 Year
<b>Rango de temperatura de Trabajo</b>	<176°F / 80°C		

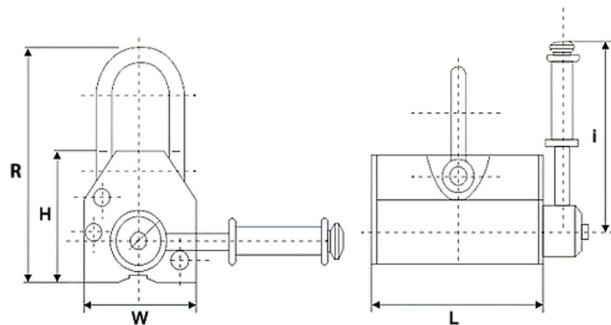

Model/Modelo	PWML100	PWML400	PWML600	PWML1000	PWML2000	PWML3000	PWML4000	PWML5000
L	4 in / 90 mm	6 in / 160 mm	9 in / 220 mm	10 in / 260 mm	13 in / 340 mm	17 in / 420 mm	19 in / 480 mm	23 in / 580 mm
W	3 in / 63.5 mm	4 in / 95 mm	5 in / 115 mm	6 in / 145 mm	6 in / 160 mm	7 in / 185 mm	8 in / 200 mm	12 in / 300 mm
H	3 in / 68 mm	7 in / 180 mm	5 in / 125 mm	6 in / 145 mm	6 in / 165 mm	7 in / 185 mm	8 in / 200 mm	12 in / 300 mm
R	6 in / 145 mm	8 in / 210 mm	9 in / 230 mm	11 in / 280 mm	16 in / 410 mm	20 in / 510 mm		26 in / 650 mm
Magnet Activation	Locking ON/OFF Handle							
Activación del magneto	Palanca ON/OFF							

## Peso & Dimensiones

**Peso Total** 8 lbs / 4 Kg

## Detalles del Empaque

**Paquete 1 Peso Neto** 6 lbs / 3 Kg

**Paquete 1 Ancho** 6 in / 15.24 cm

**Paquete 1 Peso Bruto** 8 lbs / 4 Kg

**Paquete 1 Altura** 9 in / 22.86 cm

**Paquete 1 Profundidad** 6 in / 15.24 cm

Referential Images / Imágenes Referenciales  
Specifications may change without notice / las especificaciones pueden cambiar sin previo aviso