

# 5 Ton Top Running Motorized End Trucks Single Girder up to 57ft Span 220/440V 3P

## Características Esenciales

- For heavy-duty class "C" single girder crane applications
- Drives and brakes are compatible with Variable Frequency Drive (VFD)
- Suitable for use on ASCE crane rail or square bar
- 3 Años de Garantía, Partes y Servicios Disponibles en América

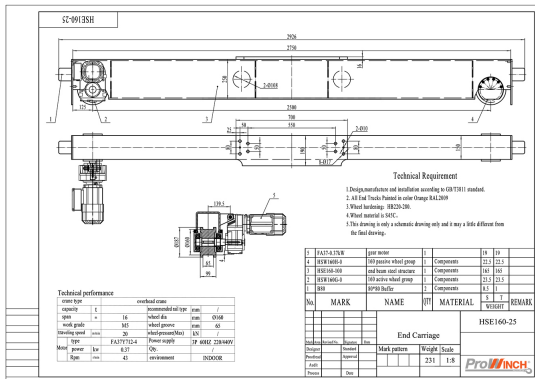

## Especificaciones Técnicas

<b>Capacidad de Carga</b>	5 Ton	<b>Freno Motor</b>	Yes
<b>Velocidad /min</b>	66 ft	<b>Protección IEC Motor</b>	IP54
<b>Numero de Velocidades</b>	1 Speed - Optional Variable Speed	<b>Variador de Frecuencia</b>	Optional 1.1 Kw
<b>Voltaje</b>	3 Phase 220~240/440~480V 60Hz	<b>Freno Dinámico</b>	Only with VFD Optional
<b>Potencia Total Watts</b>	0.37 x 2	<b>Control</b>	Not Included. Optional single Speed, 2 Speed and Variable Speed
<b>Luz Maxima</b>	53 Ft	<b>Rango de ancho de la Viga</b>	Any
<b>Material</b>	Steel	<b>Normas</b>	ASME / CMAA / Nch
<b>Clase de Servicio</b>	H4/M5/2m/Class D	<b>Garantía</b>	3 Year

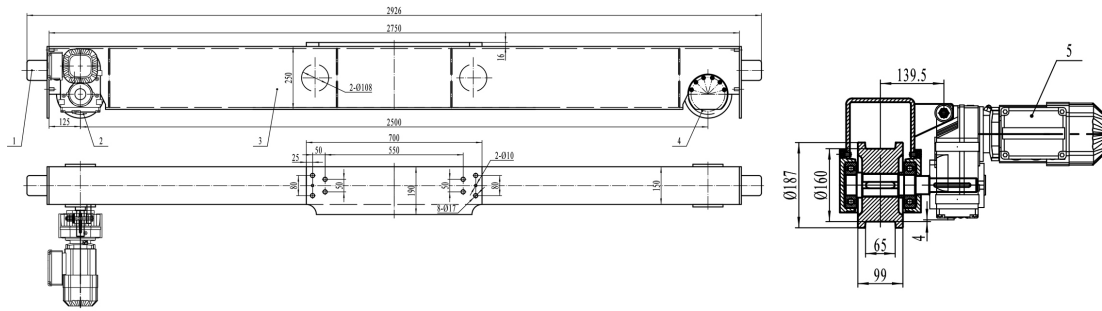

## Peso & Dimensiones

Largo de testera

2500 mm

Referential Images / Imágenes Referenciales  
 Specifications may change without notice / las especificaciones pueden cambiar sin previo aviso