

5 Ton Underhung Motorized End Trucks Single Girder up to 34ft Span 220/440V 3P

Características Esenciales

- I Beam and H Beam Compatible, Customizable up to 12" width Beams
- Kit Includes 2 End Trucks, 4 motors, 4 reducer, 4 Brakes
- Dual Voltage 220/440V 3 Phase, Optional Variable Speed Driver
- Fully Painted Orange RAL2009
- 3 Años de Garantía, Partes y Servicios Disponibles en América

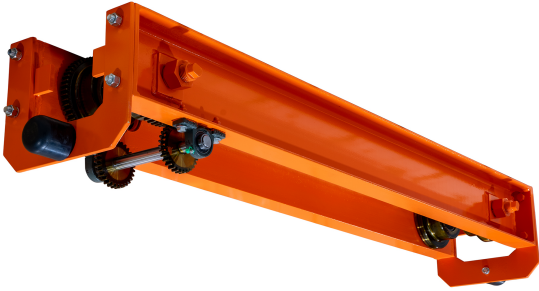

Especificaciones Técnicas

Capacidad de Carga	5 ton	Freno Motor	Yes
Velocidad /min	66 ft	Protección IEC Motor	IP54
Numero de Velocidades	1 Speed - Optional Variable Speed	Variador de Frecuencia	Optional 1.5 Kw
Voltaje	3 Phase 220~240/440~480V 60Hz	Freno Dinámico	Only with VFD Optional
Potencia Total Watts	0.25Kw x 4	Control	Not Included. Optional single Speed, 2 Speed and Variable Speed
Luz Maxima	30 ft	Rango de ancho de la Viga	120 - 350 mm (4.72 - 13.77 in)
Material	Steel	Normas	ASME / CMAA / Nch
Clase de Servicio	H4/M5/2m/Class D	Garantía	3 Year

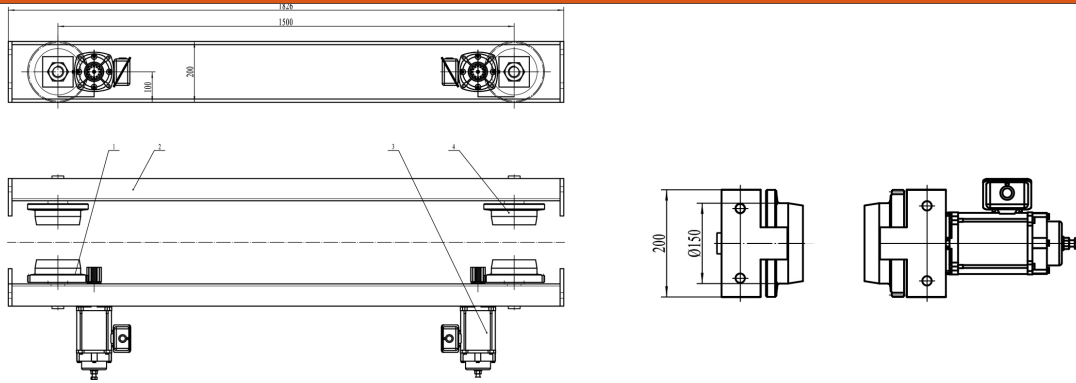

Peso & Dimensiones

Largo de testera	1500 mm
Peso Total	750 lbs / 341 Kg

Detalles del Empaque

Paquete 1 Peso Bruto	750 lbs / 340 Kg
-----------------------------	------------------

Referential Images / Imágenes Referenciales
 Specifications may change without notice / las especificaciones pueden cambiar sin previo aviso