



1,100 lbs. Davit Crane 360 Swivel Electric 110V Winch IP55

Características Esenciales

- 1 Años de Garantía, Partes y Servicios Disponibles en América

Especificaciones Técnicas

Capacidad de Carga	1100 lbs / 500 kg	Grado de Aislacion	B
Velocidad /min	33 ft/10m @1line 16ft/5m @2line	Protección IEC Motor	IP40
Numero de Velocidades	1 Speed	Cable	ø11/64 in x 38 ft ø4.3 mm x 12 m
Voltaje	1 Phase 110~120V 60Hz	Humedad	<85%
Codigo FCC	OFNF21	Temperatura	-4°~104° F / -20°~40° C
Clase de Servicio	H2/M3/1Bm/Class B	Nivel de Ruido	71 dB
Potencia Motor	1450 W	Normas	Intertek 4006091 , UL N 1340, CAN/CSA C22.2 , EN14492-2 , EN60204-32
AMP Motor	8.5 AMP	Garantía	1 Year
Freno Motor	YES		

BOOM Position	1100 lb - 0.5 t		
	1	2	3
A	1300 lbs	660 lbs	340 lbs
B	1150 lbs	580 lbs	290 lbs
C	1100 lbs	550 lbs	280 lb

BOOM Position	2200 lb - 1 t		
	1	2	3
A	2600 lbs	1300 lbs	780 lbs
B	2300 lbs	1150 lbs	690 lbs
C	2200 lbs	1100 lbs	660 lb

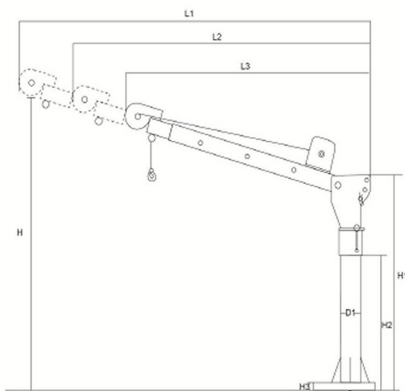

0.5t

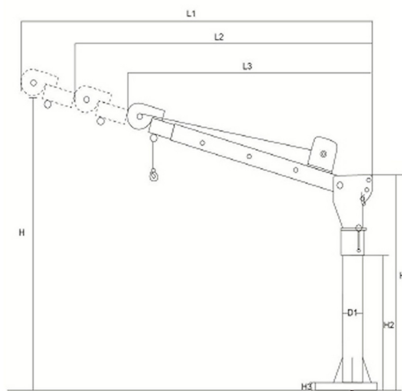

1 t

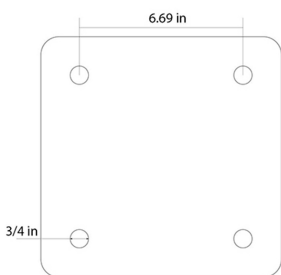

Variable	Capacity	
	1120 lb / 0.5 t	2240 lb / 1 t
H	82 in / 2082 mm	85 in / 2159 mm
H1	46.5 in / 1181 mm	47 in / 1193 mm
H2	30 in / 762 mm	
H3	3/4 in /	
L1	49 in / 1244 mm	51 in / 1295 mm
L2	42 in / 1066 mm	44 in / 1117 mm
L3	35 in / 889 mm	40 in / 1016 mm
D1	3.5 in / 88.9 mm	4 in / 101.6 mm

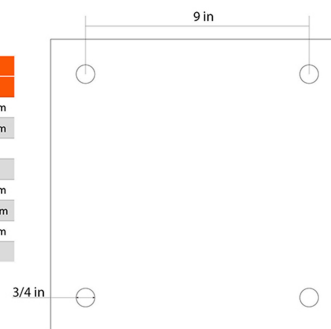

Peso & Dimensiones

Peso Total 165 lbs / 75 Kg

Detalles del Empaque

Paquete 1 Peso Neto 123 lbs / 56 Kg

Paquete 2 Peso Neto 35 lbs / 16 Kg

Paquete 1 Peso Bruto 128 lbs / 58 Kg

Paquete 2 Peso Bruto 37 lbs / 17 Kg

Paquete 1 Profundidad 54 in / 137.16 cm

Paquete 2 Profundidad 21 in / 53.34 cm

Paquete 1 Ancho 14 in / 35.56 cm

Paquete 2 Ancho 10 in / 25.4 cm

