



Tecle Cadena con Carro Electrico 10 tons 3 Fases 12 Metros 1 speed Heavy Duty

Características Esenciales

- La Calidad está adentro: Heavy Duty H3/M4. Aluminum Alloy housing, NSK Bearings, USA Chevron Meropa
- Componentes eléctricos Eaton y Schneider, Limitadores de Recorrido en todas las direcciones
- Cadena G100 Super Heavy Duty, 25% superior a la G80. Standard ASTM A973
- Estándares US y EC ASME HST-1 , ASME B30.16 , EN14492-2 , EN60204-32
- 3 Años de Garantía, Partes y Servicios Disponibles en América

Especificaciones Técnicas

Capacidad de Carga	22000 lb / 10000 kg	Hoist Contactor Brand	EATON 25 AMP
Altura de Izaje Estandar (Customizable)	40 ft / 12 m	Tipo Transmisión / Reductor	Spur gearbox with Oil splash lubrication
Velocidad /min	9ft/2.7m@60Hz 7.5ft/2.3m@50Hz	Tipo de Cadena	G100
Numero de Velocidades	1 Speed	Dimensiones de la Cadena	11.2 x 34
Voltaje	3 Phase 208~240/440~480V 50/60Hz	Caidas de Cadena	4
Voltaje para Colombia	208~240/440~480V	Longitud de cadena	160 ft / 48.5 m
Clase de Servicio	H3/M4/1Am/Class C	Humedad	<85%
Potencia Motor	3.0 kW x 2	Temperatura	-4 ~ 104° F / -20 ~ 40° C
AMP Motor	20 / 10	Potencia del Trolley	0.8 kW x 2
RPM Motor	1728@60Hz 1440@50HZ	Nivel de Ruido	81 dB
Freno Motor	Yes	Velocidad del Trolley /min	36 ft / 11 m
Grado de Aislacion	F	Cantidad de Velocidades	1
Protección IEC Motor	IP55	Rango de ancho de la Viga	100-178 mm
Control	Pendant Control and Optional Wireless	Radio Minimo de Giro	6.6 ft / 2 m
Voltaje del Control	24V	Normas	ASME HST-1 , ASME B30.16 , B30.17 , EN60204-32
Parada de Emergencia	Yes	Garantía	3 Year

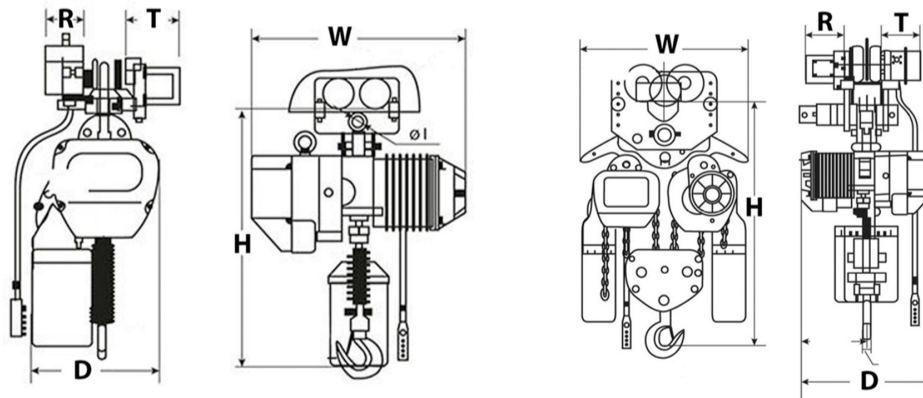

Dimensions	Model	PWRC1	PWRC2	PWRC3	PWRC5	PWRC7	PWRC10	PWRC20
	T	9.09	9.09	9.09	9.09	9.09	9.09	9.09
	H	25.5	30.5	33	40	48	55	58
	W	20.5	24.5	24	24	24	25	25
	R	5.5	5.5	5.5	5.5	5.5	5.5	5.5
	D	12	17	17	17	20	35	50



Peso & Dimensiones

Detalles del Empaque

T Motor del Carro	9.09 in / 231 mm	Paquete 1 Peso Neto	836 lbs / 379 Kg
D Depth	15 in / 380 mm	Paquete 1 Ancho	27 in / 68.58 cm
R Carro Ancho Caja	5.5 in / 142 mm	Paquete 1 Peso Bruto	900 lbs / 408 Kg
W Ancho	25 in / 630 mm	Paquete 1 Altura	36 in / 91.44 cm
H Altura Muerta	47 in / 1190 mm	Paquete 1 Profundidad	37 in / 93.98 cm
J Boca Gancho	70		
Peso Total	900 lbs / 409 Kg		