



## 12 Ton Air Chain Hoist - 12 meters lifting height - RUD G80 Chain

### Características Esenciales

- 3 Años de Garantía, Partes y Servicios Disponibles en América

## Especificaciones Técnicas

<b>Pendant Control Yes No</b>	Included	<b>Control</b>	Pendant Control w/emergency stop
<b>Pendant Control Emergency Stop</b>	Yes	<b>Parada de Emergencia</b>	Yes
<b>Capacidad de Carga</b>	12 ton	<b>Normas</b>	ASME B30.11 /B30.16 /HST-5 DIN EN818-7 SANS 1638 compliant ATEX EX Classification according to EC Directive on Hazardous Locations 94/9/EEC
<b>Altura de Izaje Estandar (Customizable)</b>	20 ft / 6 m	<b>Garantía</b>	3 Year
<b>Numero de Velocidades</b>	1 Speed	<b>IEC Pendant Control Protection</b>	IP66
<b>Clase de Servicio</b>	100% Duty Cycle	<b>Protección Antiexplosión</b>	- EX 2 GD IIA T4 - EX 2 GD IIB T4 - EXCLUDES Hydrogen Disulphide or Ethelene Oxide - ZONES 1, 2 AND 21, 22
<b>Tipo de Motor</b>	Vane Rotary Motor - Lubrication Free - Rust Free & Replaceable Stainless Steel Cylinder	<b>Fabricado en</b>	South Africa
<b>Freno Motor</b>	>125% WLL Automatic self-adjusting multidisc Brake		

PWRN models

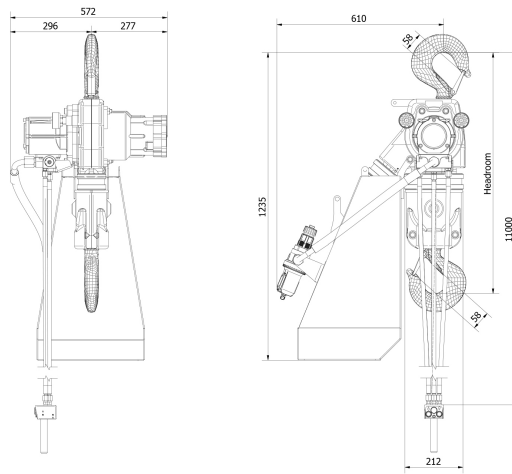

Referential Images / Imágenes Referenciales  
Specifications may change without notice / las especificaciones pueden cambiar sin previo aviso