



1/2 ton Electric Chain Hoist 1 Speed 208~240V / 440~480V 3ph 60HZ

Características Esenciales

- 3 Años de Garantía, Partes y Servicios Disponibles en América

1/2 ton Electric Chain Hoist 1 Speed 208~240V / 440~480V 3ø 60HZ 13ft G100 Nickel Duty H4/M5

Especificaciones Técnicas

Recommended Hoist Protection Circuit Breaker AMPs and Type	Type D 15A at 220V and 10A at 460V	Clase de Servicio	H4/M5/2m/Class D
Power Cord Length and Phase Order	3 ft / Black L1 , Red L2 and Blue L3 [Green ground	Tipo de Motor	TEFC
Pendant Control Yes No	Included	Protección IEC Motor	IP55
Pendant Control Emergency Stop	Yes	Control	Pendant Control IP66 and Optional Wireless
Paint Specifications	Electrostatic Sprayed Plastic (ESP) Epoxy resins, Polyester Resins, Barium, Pigments	Voltaje del Control	48V
Overload Protection	Overload Motor Clutch	Parada de Emergencia	Yes
Optional Load Chain Brand & Country of Origin	FEC Japan	Hoist Contactor Brand	Schneider
Standards Certified	CE	Tipo Transmisión / Reductor	Spur gearbox
Brake SKU	PWRX-0.25-0.5-PN.4.11	Tipo de Cadena	G100 Nikel
Brake rectifiers-half-wave	PWRX-BKTF-HW	Dimensiones de la Cadena	6.3mm
Capacidad de Carga	1/2 ton	Caidas de Cadena	1
Altura de Izaje Estandar (Customizable)	13 ft / 4 m	Longitud de cadena	13
Velocidad /min	31.49 ft @60Hz 8 mt @50Hz	Humedad	20%~90%
Numero de Velocidades	1 Speed	Temperatura	-4 ~ 104° F / -20 ~ 40° C
Voltaje	3 Phase 208~240/440~480V 50/60Hz	Normas	ASME HST-1 , ASME B30.16 , EN60204-37
Potencia Total Watts	750	Garantía	3 Year

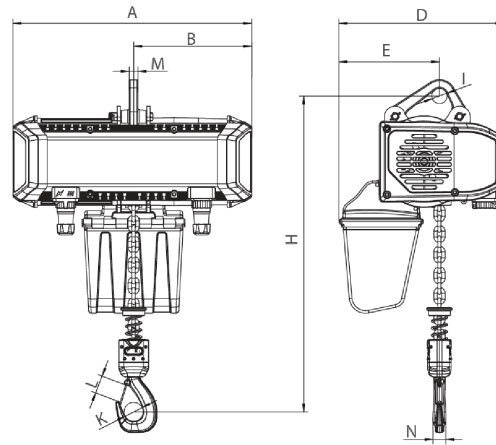

[Size list: mm]

Rated load (t)	Type	Minimum distance between hooks: H	A	B	D	E	I	M	N	K	L
0.25-0.5	PWRXF0.25-0.5-VS	399	447	217	337	179	31	16	20	35	31

Peso & Dimensiones

H Altura Muerta	396
W Ancho	305
A Altura Total	396
J Boca Gancho	35
D Depth	440
Peso Total (sin cable o cadena)	53
Peso Total	74.8 lbs / 34 Kg

Detalles del Empaque

Paquete 1 Peso Neto	61.16 lbs / 28 Kg
Paquete 1 Ancho	15 in / 38.1 cm
Paquete 1 Peso Bruto	74.8 lbs / 34 Kg
Paquete 1 Altura	20 in / 50.8 cm
Paquete 1 Profundidad	20 in / 50.8 cm

Referential Images / Imágenes Referenciales
Specifications may change without notice / las especificaciones pueden cambiar sin previo aviso