



3 ton Electric Chain Hoist 1 Speed 208~240V / 440~480V 3ph 60HZ

Características Esenciales

- 3 Años de Garantía, Partes y Servicios Disponibles en América

3 ton Electric Chain Hoist 1 Speed 208~240V / 440~480V 3ph 60HZ

Especificaciones Técnicas

Recommended Hoist Protection Circuit Breaker AMPs and Type	Type D 25A at 220V and 20A at 460V	Clase de Servicio	H4/M5/2m/Class D
Power Cord Length and Phase Order	3 ft / Black L1 , Red L2 and Blue L3 [Green ground	Tipo de Motor	TEFC
Pendant Control Yes No	Included	Protección IEC Motor	IP55
Pendant Control Emergency Stop	Yes	Control	Pendant Control IP66 and Optional Wireless
Paint Specifications	Electrostatic Sprayed Plastic (ESP) Epoxy resins, Polyester Resins, Barium, Pigments	Voltaje del Control	24V
Overload Protection	Overload Motor Clutch	Parada de Emergencia	Yes
Optional Load Chain Brand & Country of Origin	FEC Japan	Hoist Contactor Brand	Schneider
Standards Certified	CE	Tipo Transmisión / Reductor	Spur gearbox
Brake SKU	PWRX-2-20-PN.60.61	Tipo de Cadena	G100 Nikel
Brake rectifiers-half-wave	PWRX-BKTF-HW	Dimensiones de la Cadena	11.2 mm
Capacidad de Carga	3 ton	Caidas de Cadena	1
Altura de Izaje Estandar (Customizable)	30 ft / 9 m	Longitud de cadena	30
Velocidad /min	21.25 ft @60Hz 5.40 mt @50Hz	Humedad	20%~90%
Numero de Velocidades	1 Speed	Temperatura	-4 ~ 104° F / -20 ~ 40° C
Voltaje	3 Phase 208~240/440~480V 50/60Hz	Normas	ASME HST-1 , ASME B30.16 , EN60204-35
Potencia Total Watts	3000	Garantía	3 Year

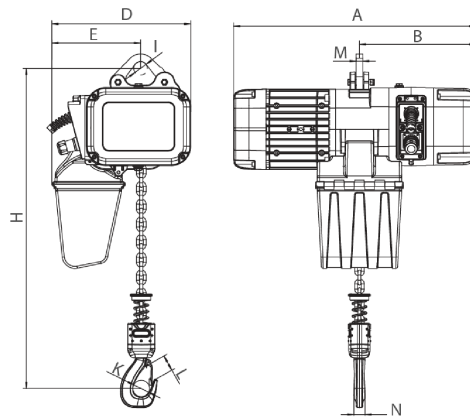

[Size list: mm]

Rated load (t)	Type	Minimum distance between hooks: H	A	B	D	E	I	M	N	K	L
1	PWRXF1-01	455	590	276	330	210	32	16	25	42	32
2	PWRXF2-01	550	590	276	330	210	38	20	35	52	42
3	PWRXF3-01	560	695	350	420	265	45	20	34	59	48
5	PWRXF5-02	675	695	350	420	307	55	28	44	60	48

Peso & Dimensiones

H Altura Muerta	645
W Ancho	420
A Altura Total	560
J Boca Gancho	59
D Depth	695
Peso Total (sin cable o cadena)	130
Peso Total	209 lbs / 95 Kg

Detalles del Empaque

Paquete 1 Peso Neto	184.8 lbs / 84 Kg
Paquete 1 Ancho	20 in / 50.8 cm
Paquete 1 Peso Bruto	209 lbs / 95 Kg
Paquete 1 Altura	31 in / 78.74 cm
Paquete 1 Profundidad	30 in / 76.2 cm

Referential Images / Imágenes Referenciales
Specifications may change without notice / las especificaciones pueden cambiar sin previo aviso