



1/2 ton Electric Chain Hoist w/ Power Trolley 1 Speed 208~240V / 440~480V 3 ϕ 1/2 60HZ 13ft G100 Nickel Duty H4/M5

Características Esenciales

- 3 Años de Garantía, Partes y Servicios Disponibles en América

Especificaciones Técnicas

Paint Specifications	Electrostatic Sprayed Plastic (ESP) Epoxy resins, Polyester Resins, Barium, Pigments	Brake rectifiers-full-wave	PWRX-BKTF-FW
Hoist UL Components	UL Listed Contactors	Hoist Motor Brake Type and DC Voltage	DC99V/DC207V
Trolley Beam Extension Kit	up to 12"	Hour Meter	Internal Working Hour Meter
Trolley Beam Range	3" to 5"	Hoist Motor Power in KW	0.75
Trolley Minimum Turn Radius	1.3	IEC Pendant Control Protection	IP66
Trolley Wheel Diameter	95	Altura de Izaje Estandar (Customizable)	13 ft / 4 m
Trolley Wheel Material	No. 45 steel	Velocidad /min	31.49 ft @60Hz 8 mt @50Hz
Trolley Contactors Coil Voltage	48V	Numero de Velocidades	1 Speed
Trolley UL Component	UL Listed	Voltaje	3 Phase 208~240/440~480V 50/60Hz
Trolley Contactors Brand	Schneider	Potencia Total Watts	1000
Trolley Contactors Amps	20A	Clase de Servicio	H4/M5/2m/Class D
Trolley Motor Insulation Grade	F	Protección IEC Motor	IP55
Trolley Motor Brake Type and DC Voltage	DC99V/DC207V	Control	Pendant Control IP66
Optional Load Chain Brand & Country of Origin	FEC Japan	Voltaje del Control	48V
Recommended Hoist Protection Circuit Breaker AMPs and Type	Type D 15A at 220V and 10A at 460V	Parada de Emergencia	Yes
Power Cord Length and Phase Order	3 ft / Black L1 , Red L2 and Blue L3 Green ground	Hoist Contactor Brand	Schneider
Brake rectifiers-half-wave	PWRX-BKTF-HW	Tipo Transmisión / Reductor	Spur gearbox
Overload Protection	Overload Motor Clutch	Tipo de Cadena	G100 Nickel
Pendant Control Emergency Stop	Yes	Dimensiones de la Cadena	6.3mm
Pendant Control Yes No	Yes	Caidas de Cadena	1
Capacidad de Carga	1/2 ton	Longitud de cadena	13
Hoist Contactors Amps	10A	Humedad	20%~90%
Hoist Contactor Coil Voltage	48V	Temperatura	-4 ~ 104° F / -20 ~ 40° C
IEC Hoist IP Protection	IP55	Potencia del Trolley	500
2nd Package Type	Wood Crate	Velocidad del Trolley /min	43.30 ft @60Hz 11 mt @50Hz
1st Package Type	Wood Crate	Cantidad de Velocidades	1
Reducer Lubrication Type	Oil	Normas	ASME HST-1 , ASME B30.16 , EN60204-37
Load Chain weight per foot [lbs]	0.58	Garantía	3 Year
Hoist Motor Insulation Grade	F		

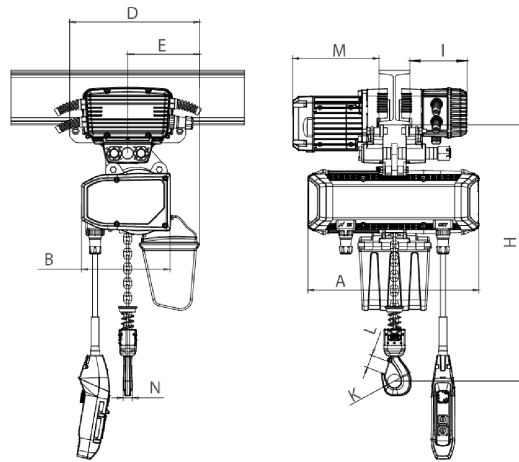

Rated load (t)	Type	Dimension (mm)									
		Minimum distance from the bottom of the track to the bottom hook: H	A	L	B	D	E	I	M	N	K
0.25-0.5	PWRXT0.25-0.5-VS	473	447	3500-5500	217	334	152	147	220	20	35

Peso & Dimensiones

Peso Total 211.4 lbs / 96 Kg

Detalles del Empaque

H Altura Muerta 15.59

W Ancho 12.01

A Altura Total 15.59

J Boca Gancho 1.38

D Depth 17.32

Peso Total (sin cable o cadena) 113.49

Referential Images / Imágenes Referenciales
Specifications may change without notice / las especificaciones pueden cambiar sin previo aviso