



1 ton Electric Chain Hoist w/ Power Trolley 2 Speed 208~240V / 440~480V 3ph 60HZ

Características Esenciales

- 3 Años de Garantía, Partes y Servicios Disponibles en América

1 ton Electric Chain Hoist w/ Power Trolley 2 Speed 208~240V / 440~480V 3ø 60HZ 20ft G100 Nickel Duty H4/M5

Especificaciones Técnicas

Capacidad de Carga	1 ton	Load Chain weight per foot [lbs]	0.74
Voltaje	3 Phase 208~240/440~480V 50/60Hz	Humedad	20%~90%
Altura de Izaje Estandar (Customizable)	Up to 20 ft / 6 m	Temperatura	-4 ~ 104° F / -20 ~ 40° C
Velocidad /min	7.9/ 42.7 ft @60Hz 2/6.5 mt @50Hz	Tipo Transmisión / Reductor	Spur gearbox
Numero de Velocidades	2 Speed	Reducer Lubrication Type	Oil
Hoist Contactors Amps	18A	Paint Specifications	Electrostatic Sprayed Plastic (ESP) Epoxy resins, Polyester Resins, Barium, Pigments
Hoist Contactor Brand	Schneider	Normas	ASME HST-1 , ASME B30.16 , B30.17 , EN60204-33
Hoist Contactor Coil Voltage	24 V	Standards Certified	CE
Clase de Servicio	H4/M5/2m/Class D	Potencia del Trolley	500
IEC Hoist IP Protection	IP55	Cantidad de Velocidades	2
Protección IEC Motor	IP55	Velocidad del Trolley /min	14.17~43.30 ft @60Hz 3.6~11 mt @50Hz
Pendant Control Yes No	Yes	Trolley Motor Brake Type and DC Voltage	DC99V/DC207V
IEC Pendant Control Protection	IP66	Trolley Motor Insulation Grade	F
Pendant Control Emergency Stop	Yes	Trolley Contactors Amps	32A
Pendant Control total Length	17 ft	Trolley Contactors Brand	Schneider
Hoist Motor Power in KW	1.5	Trolley Contactors Coil Voltage	24 V
Hoist Motor Brake Type and DC Voltage	DC99V/DC207V	Trolley Wheel Diameter	95
Hoist Motor Insulation Grade	F	Trolley Wheel Material	No. 45 steel
Potencia Total Watts	2000	Trolley Minimum Turn Radius	1.3
Power Cord Length and Phase Order	3 ft / Black L1 , Red L2 and Blue L3 □Green ground	Trolley Beam Range	2" to 6"
Recommended Hoist Protection Circuit Breaker AMPs and Type	Type D 20A at 220V and 15A at 460V	Trolley Beam Extension Kit	up to 12"
Optional Load Chain Brand & Country of Origin	FEC Japan	Overload Protection	Overload Motor Clutch
Tipo de Cadena	G100 Nikel	Hour Meter	Internal Working Hour Meter
Dimensiones de la Cadena	7.1 mm	Brake SKU	PWRX-1-PN.60.61
Caidas de Cadena	1	Brake rectifiers-half-wave	PWRX-BKTF-HW
Longitud de cadena	20	Brake rectifiers-full-wave	PWRX-BKTF-FW

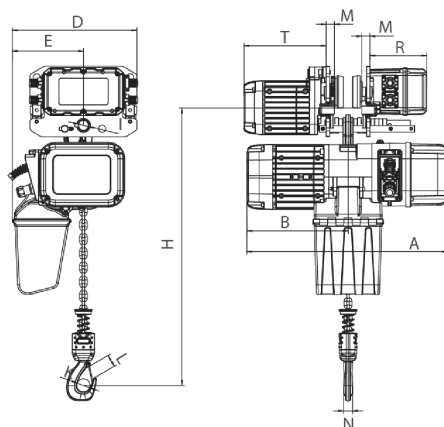

Rated load (t)	Type	Dimension (mm)												
		Minimum distance from the bottom of the track to the bottom hook: H	A	L	B	D	E	I	M	N	K	L	T	R
1	PWRXT1-01	473	440	3500-5500	285	210	20	105	140					
2	PWRXT2-01	516	590		276	368	210	31	24	25	42	32	242	167
3	PWRXT3-01	600	681		350	422	264	36	28	35	52	42	242	167
5	PWRXT5-02	645	681		350	478	307	43	30	34	59	48	242	167

Peso & Dimensiones

A Altura Total	516
J Boca Gancho	42
W Ancho	368
H Altura Muerta	516
D Depth	590
1st Package Type	Wood Crate
Peso Total (sin cable o cadena)	86
2nd Package Type	Wood Crate
Peso Total	330 lbs / 150 Kg

Detalles del Empaque

Paquete 1 Altura	26 in / 66.04 cm
Paquete 2 Altura	23 in / 58.42 cm
Paquete 1 Ancho	16 in / 40.64 cm
Paquete 2 Ancho	14 in / 35.56 cm
Paquete 1 Profundidad	26 in / 66.04 cm
Paquete 2 Profundidad	11 in / 27.94 cm
Paquete 1 Peso Neto	101.64 lbs / 46 Kg
Paquete 2 Peso Neto	111.1 lbs / 50 Kg
Paquete 1 Peso Bruto	209 lbs / 95 Kg
Paquete 2 Peso Bruto	121 lbs / 55 Kg

