



## 20 ton Electric Chain Hoist w/ Power Trolley Variable Speed Trolley 208~240V / 440~480V 3Ø 60HZ 40ft G100 Nickel Duty H4/M5

### Características Esenciales

- 3 Años de Garantía, Partes y Servicios Disponibles en América

## Especificaciones Técnicas

<b>Optional Load Chain Brand &amp; Country of Origin</b>	FEC Japan	<b>Velocidad /min</b>	5.31 ft @60Hz 1.35 mt @50Hz
<b>Standards Certified</b>	CE	<b>Numero de Velocidades</b>	1 Speed
<b>Recommended Hoist Protection Circuit Breaker AMPs and Type</b>	Type D 50A at 220V and 30A at 460V	<b>Voltaje</b>	3 Phase 208~240/440~480V 50/60Hz
<b>Power Cord Length and Phase Order</b>	3 ft / Black L1 , Red L2 and Blue L3 Green ground	<b>Potencia Total Watts</b>	7500
<b>Pendant Control Yes No</b>	Yes	<b>Clase de Servicio</b>	H4/M5/2m/Class D
<b>Pendant Control Emergency Stop</b>	Yes	<b>Protección IEC Motor</b>	IP55
<b>Paint Specifications</b>	Electrostatic Sprayed Plastic (ESP) Epoxy resins, Polyester Resins, Barium, Pigments	<b>Control</b>	Pendant Control IP66 and Optional Wireless
<b>Overload Protection</b>	Overload Motor Clutch	<b>Voltaje del Control</b>	24V
<b>Trolley Beam Extension Kit</b>	up to 12"	<b>Parada de Emergencia</b>	Yes
<b>Brake SKU</b>	PWRX-2-20-PN.60.61	<b>Hoist Contactor Brand</b>	Schneider
<b>Trolley Wheel Material</b>	No. 45 steel	<b>Tipo Transmisión / Reductor</b>	Spur gearbox
<b>Trolley Wheel Diameter</b>	139	<b>Tipo de Cadena</b>	G100 Nikel
<b>Trolley VFD Power in KW</b>	2.5kW	<b>Dimensiones de la Cadena</b>	11.2 mm
<b>Trolley VFD Model</b>	huayuan	<b>Caidas de Cadena</b>	8
<b>Trolley VFD Brand</b>	z-230	<b>Longitud de cadena</b>	320
<b>Trolley Motor Insulation Grade</b>	F	<b>Humedad</b>	20%~90%
<b>Trolley Motor Brake Type and DC Voltage</b>	DC99V/DC207V	<b>Temperatura</b>	-4 ~ 104° F / -20 ~ 40° C
<b>Trolley Minimum Turn Radius</b>	2.2	<b>Potencia del Trolley</b>	750+750
<b>Trolley Beam Range</b>	5.9" to 8.6"	<b>Velocidad del Trolley /min</b>	2.75~27.55 ft @60Hz 0.7~7 mt @50Hz
<b>Brake rectifiers-half-wave</b>	PWRX-BKTF-HW	<b>Cantidad de Velocidades</b>	Variable
<b>Capacidad de Carga</b>	20 ton	<b>Normas</b>	ASME HST-1 , ASME B30.16 , B30.17 , EN60204-39
<b>Altura de Izaje Estandard (Customizable)</b>	40 ft / 12 m	<b>Garantía</b>	3 Year

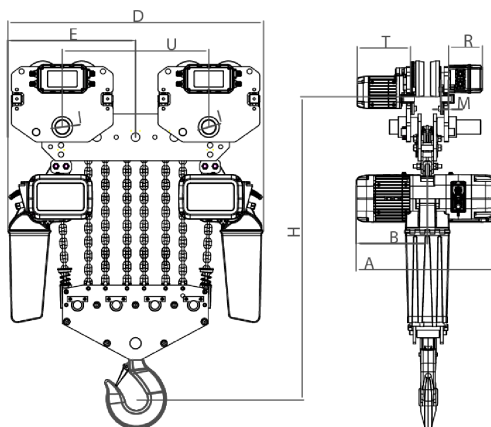

Rated load (t)	Type	Dimension (mm)												
		Minimum distance from the bottom of the track to the bottom hook: H	A	L	B	D	E	I	M	N	K	L	T	R
20	PWRXT20-08	1300	700	3500-5500	350	1246	623	71	40	80	120	96	242	167

## Peso & Dimensiones

<b>H Altura Muerta</b>	1240
<b>W Ancho</b>	1246
<b>A Altura Total</b>	1300
<b>J Boca Gancho</b>	120
<b>D Depth</b>	700
<b>Peso Total (sin cable o cadena)</b>	845
<b>Peso Total</b>	1848 lbs / 839 Kg

## Detalles del Empaque

<b>Paquete 1 Peso Neto</b>	1430 lbs / 649 Kg
<b>Paquete 2 Peso Neto</b>	345.4 lbs / 157 Kg
<b>Paquete 1 Peso Bruto</b>	1474 lbs / 669 Kg
<b>Paquete 2 Peso Bruto</b>	374 lbs / 170 Kg
<b>Paquete 1 Profundidad</b>	55 in / 139.7 cm
<b>Paquete 2 Profundidad</b>	11 in / 27.94 cm
<b>Paquete 1 Ancho</b>	30 in / 76.2 cm
<b>Paquete 2 Ancho</b>	14 in / 35.56 cm
<b>Paquete 1 Altura</b>	51 in / 129.54 cm
<b>Paquete 2 Altura</b>	23 in / 58.42 cm

Referential Images / Imágenes Referenciales  
Specifications may change without notice / las especificaciones pueden cambiar sin previo aviso