



5 ton Electric Chain Hoist w/ Power Trolley 1 Speed 208~240V / 440~480V 3ph 60HZ

Características Esenciales

- 3 Años de Garantía, Partes y Servicios Disponibles en América

PWRTX5-H4-1S-2/4

Especificaciones Técnicas

Optional Load Chain Brand & Country of Origin	FEC Japan	Velocidad /min	10.63 ft @60Hz 2.70 mt @50Hz
Standards Certified	CE	Numero de Velocidades	1 Speed
Recommended Hoist Protection Circuit Breaker AMPs and Type	Type D 25A at 220V and 20A at 460V	Voltaje	3 Phase 208~240/440~480V 50/60Hz
Power Cord Length and Phase Order	3 ft / Black L1 , Red L2 and Blue L3 Green ground	Potencia Total Watts	4000
Pendant Control Yes No	Yes	Clase de Servicio	H4/M5/2m/Class D
Pendant Control Emergency Stop	Yes	Protección IEC Motor	IP55
Paint Specifications	Electrostatic Sprayed Plastic (ESP) Epoxy resins, Polyester Resins, Barium, Pigments	Control	Pendant Control IP66 and Optional Wireless
Overload Protection	Overload Motor Clutch	Voltaje del Control	24V
Trolley Beam Extension Kit	up to 12"	Parada de Emergencia	Yes
Brake SKU	PWRX-2-20-PN.60.61	Tipo Transmisión / Reductor	Spur gearbox
Trolley Wheel Material	No. 45 steel	Tipo de Cadena	G100 Nikel
Trolley Wheel Diameter	139	Dimensiones de la Cadena	11.2 mm
Trolley Motor Insulation Grade	F	Caidas de Cadena	2
Trolley Motor Brake Type and DC Voltage	DC99V/DC207V	Longitud de cadena	60
Trolley Minimum Turn Radius	1.8	Humedad	20%~90%
Trolley Contactors Coil Voltage	24 V	Temperatura	-4 ~ 104° F / -20 ~ 40° C
Trolley Contactors Brand	Schneider	Potencia del Trolley	750
Trolley Contactors Amps	40A	Velocidad del Trolley /min	43.30 ft @60Hz 11 mt @50Hz
Trolley Beam Range	3.9" to 7"	Cantidad de Velocidades	1
Brake rectifiers-half-wave	PWRX-BKTF-HW	Normas	ASME HST-1 , ASME B30.16 , B30.17 , EN60204-36
Capacidad de Carga	5 ton	Garantía	3 Year
Altura de Izaje Estandard (Customizable)	30 ft / 9 m		

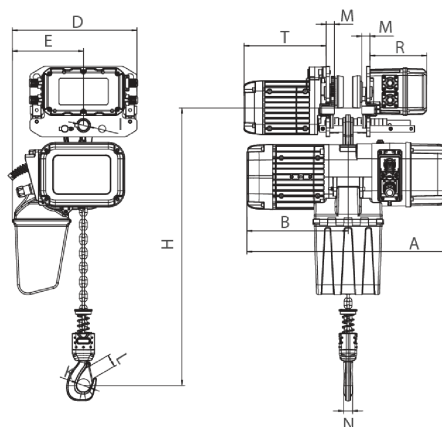

Rated load (t)	Type	Dimension (mm)												
		Minimum distance from the bottom of the track to the bottom hook: H	A	L	B	D	E	I	M	N	K	L	T	R
1	PWRXT1-01	473	440	3500-5500	285	210	20	105	140					
2	PWRXT2-01	516	590		276	368	210	31	24	25	42	32	242	167
3	PWRXT3-01	600	681		350	422	264	36	28	35	52	42	242	167
5	PWRXT5-02	645	681		350	478	307	43	30	34	59	48	242	167

Peso & Dimensiones

H Altura Muerta	810
W Ancho	420
A Altura Total	675
J Boca Gancho	60
D Depth	695
Peso Total (sin cable o cadena)	185
Peso Total	544 lbs / 247 Kg

Detalles del Empaque

Paquete 1 Peso Neto	294.8 lbs / 134 Kg
Paquete 1 Ancho	24 in / 60.96 cm
Paquete 1 Peso Bruto	544 lbs / 247 Kg
Paquete 1 Altura	44 in / 111.76 cm
Paquete 1 Profundidad	30 in / 76.2 cm

Referential Images / Imágenes Referenciales
Specifications may change without notice / las especificaciones pueden cambiar sin previo aviso