

**7.5 ton Electric Chain Hoist w/  
Power Trolley Variable Speed  
440~480V 3 $\phi$  1/2 50~60HZ**

## Especificaciones Técnicas

<b>Capacidad de Carga</b>	7.5 ton	<b>Dimensiones de la Cadena</b>	11.2 mm
<b>Voltaje</b>	3 Phase 440~480V 60Hz	<b>Caidas de Cadena</b>	3
<b>Altura de Izaje Estandar (Customizable)</b>	30 ft / 9 m	<b>Longitud de cadena</b>	90
<b>Velocidad /min</b>	1.1~7 ft @60Hz mt @50Hz	<b>Load Chain weight per foot [lbs]</b>	1.83
<b>Numero de Velocidades</b>	Variable Speed	<b>Humedad</b>	20%~90%
<b>Hoist VFD Power</b>	4kW	<b>Temperatura</b>	-4 ~ 104° F / -20 ~ 40° C
<b>Hoist VFD Brand</b>	HUAYUAN	<b>Tipo Transmisión / Reductor</b>	Spur gearbox
<b>VFD Model</b>	Z230	<b>Reducer Lubrication Type</b>	Oil
<b>Brake Resistor Kw</b>	1Kw	<b>Paint Specifications</b>	Electrostatic Sprayed Plastic (ESP) Epoxy resins, Polyester Resins, Barium, Pigments
<b>Clase de Servicio</b>	H4/M5/2m/Class D	<b>Normas</b>	ASME HST-1 , ASME B30.16 , B30.17 , EN60204-37
<b>IEC Hoist IP Protection</b>	IP55	<b>Standards Certified</b>	CE
<b>Protección IEC Motor</b>	IP55	<b>Potencia del Trolley</b>	750
<b>Pendant Control Yes No</b>	Yes	<b>Cantidad de Velocidades</b>	Variable
<b>IEC Pendant Control Protection</b>	IP66	<b>Velocidad del Trolley /min</b>	5.9~47.23 ft @60Hz 1.5~12 mt @50Hz
<b>Pendant Control Emergency Stop</b>	Yes	<b>Trolley Motor Brake Type and DC Voltage</b>	DC207V
<b>Pendant Control total Length</b>	27 ft	<b>Trolley Motor Insulation Grade</b>	F
<b>Hoist Motor Power in KW</b>	3	<b>Trolley VFD Power in KW</b>	2.5kW
<b>Hoist Motor Brake Type and DC Voltage</b>	DC207V	<b>Trolley VFD Brand</b>	Huayuan
<b>Hoist Motor Insulation Grade</b>	F	<b>Trolley VFD Model</b>	Z230
<b>Potencia Total Watts</b>	4000	<b>Trolley Wheel Diameter</b>	139
<b>Power Cord Length and Phase Order</b>	3 ft / Black L1 , Red L2 and Blue L3 Green ground	<b>Trolley Wheel Material</b>	No. 45 steel
<b>Recommended Hoist Protection Circuit Breaker AMPs and Type</b>	Type D 20A	<b>Trolley Minimum Turn Radius</b>	1.8
<b>Optional Load Chain Brand &amp; Country of Origin</b>	FEC Japan	<b>Trolley Beam Range</b>	3.9" to 7"
<b>Tipo de Cadena</b>	G100 Nikel	<b>Trolley Beam Extension Kit</b>	up to 12"

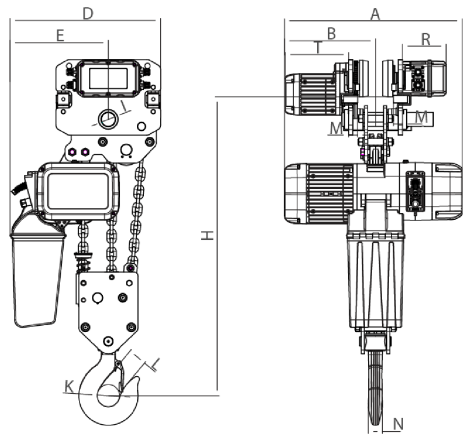

Rated load (t)	Type	Dimension (mm)												
		Minimum distance from the bottom of the track to the bottom hook: H	A	L	B	D	E	I	M	N	K	L	T	R
7	PWRXT7-03	1020	681	3500-5500	350	579	375	54	35	48	85	80	242	167

## Peso & Dimensiones

<b>A Altura Total</b>	1020
<b>J Boca Gancho</b>	85
<b>W Ancho</b>	576
<b>H Altura Muerta</b>	1170
<b>D Depth</b>	681
<b>1st Package Type</b>	Wood Crate
<b>Peso Total (sin cable o cadena)</b>	130
<b>2nd Package Type</b>	Wood Crate
<b>Peso Total</b>	869 lbs / 395 Kg

## Detalles del Empaque

<b>Paquete 1 Altura</b>	31 in / 78.74 cm
<b>Paquete 2 Altura</b>	23 in / 58.42 cm
<b>Paquete 1 Ancho</b>	20 in / 50.8 cm
<b>Paquete 2 Ancho</b>	14 in / 35.56 cm
<b>Paquete 1 Profundidad</b>	30 in / 76.2 cm
<b>Paquete 2 Profundidad</b>	11 in / 27.94 cm
<b>Paquete 1 Peso Neto</b>	294.8 lbs / 134 Kg
<b>Paquete 2 Peso Neto</b>	345.4 lbs / 157 Kg
<b>Paquete 1 Peso Bruto</b>	495 lbs / 225 Kg
<b>Paquete 2 Peso Bruto</b>	374 lbs / 170 Kg

Referential Images / Imágenes Referenciales  
Specifications may change without notice / las especificaciones pueden cambiar sin previo aviso